

Stage 0: Isolate Immunization Obs terms

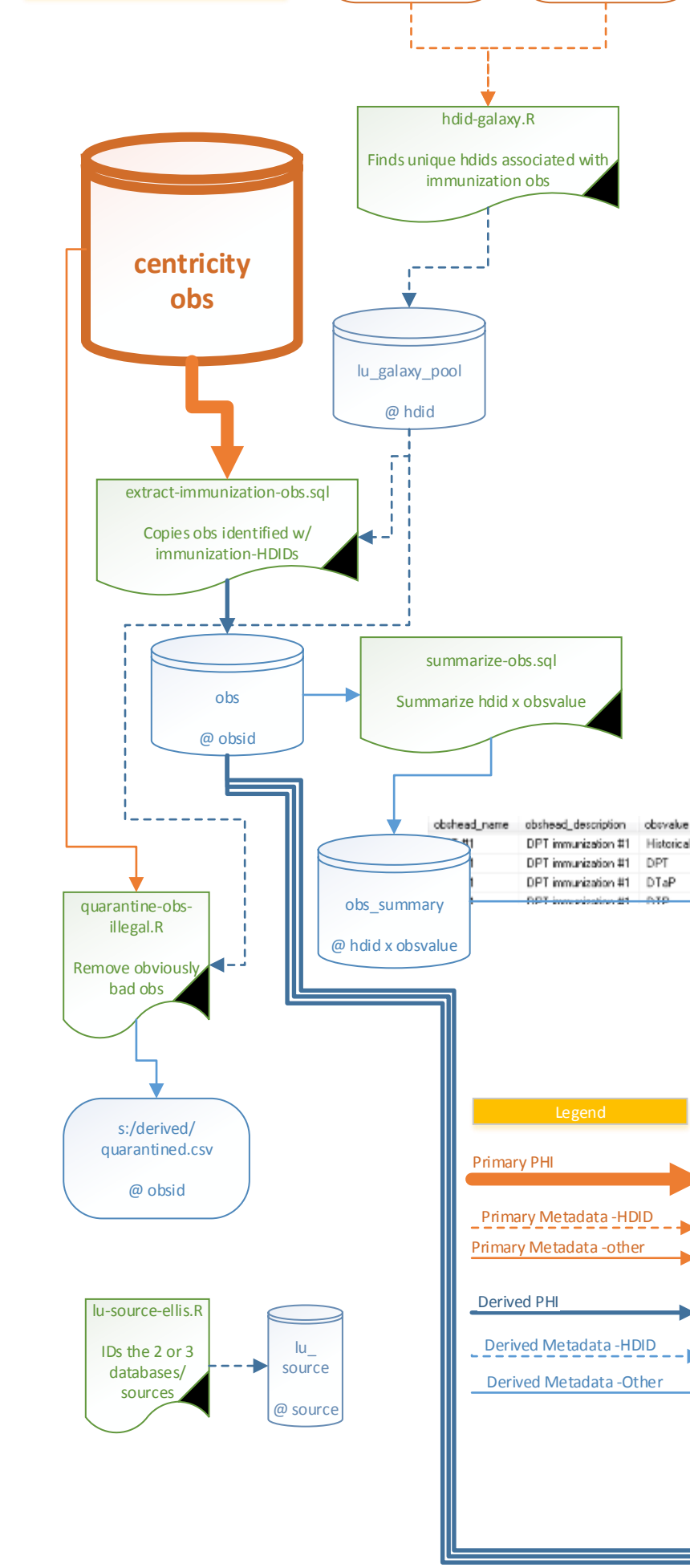

Stage 1: Initialize HDID Metadata

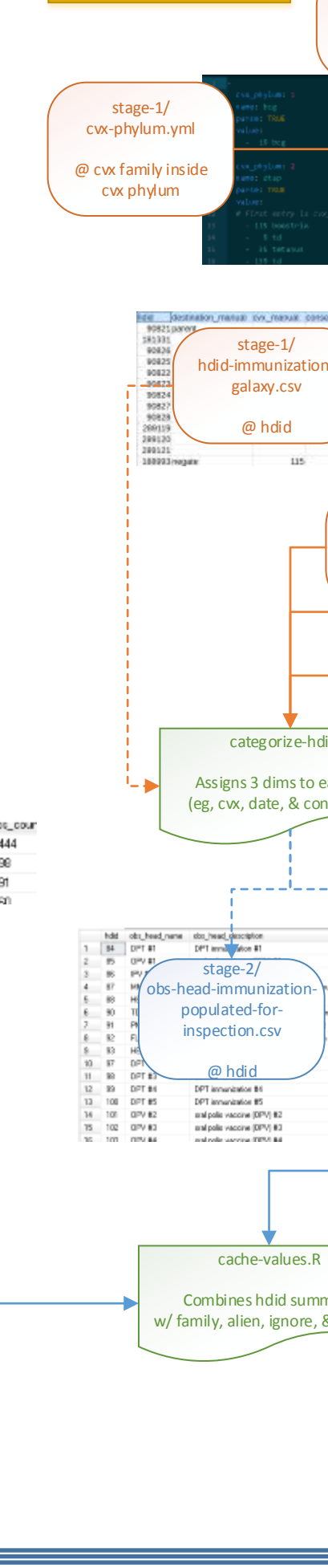

Stage 2: Match Obsvalue Patterns

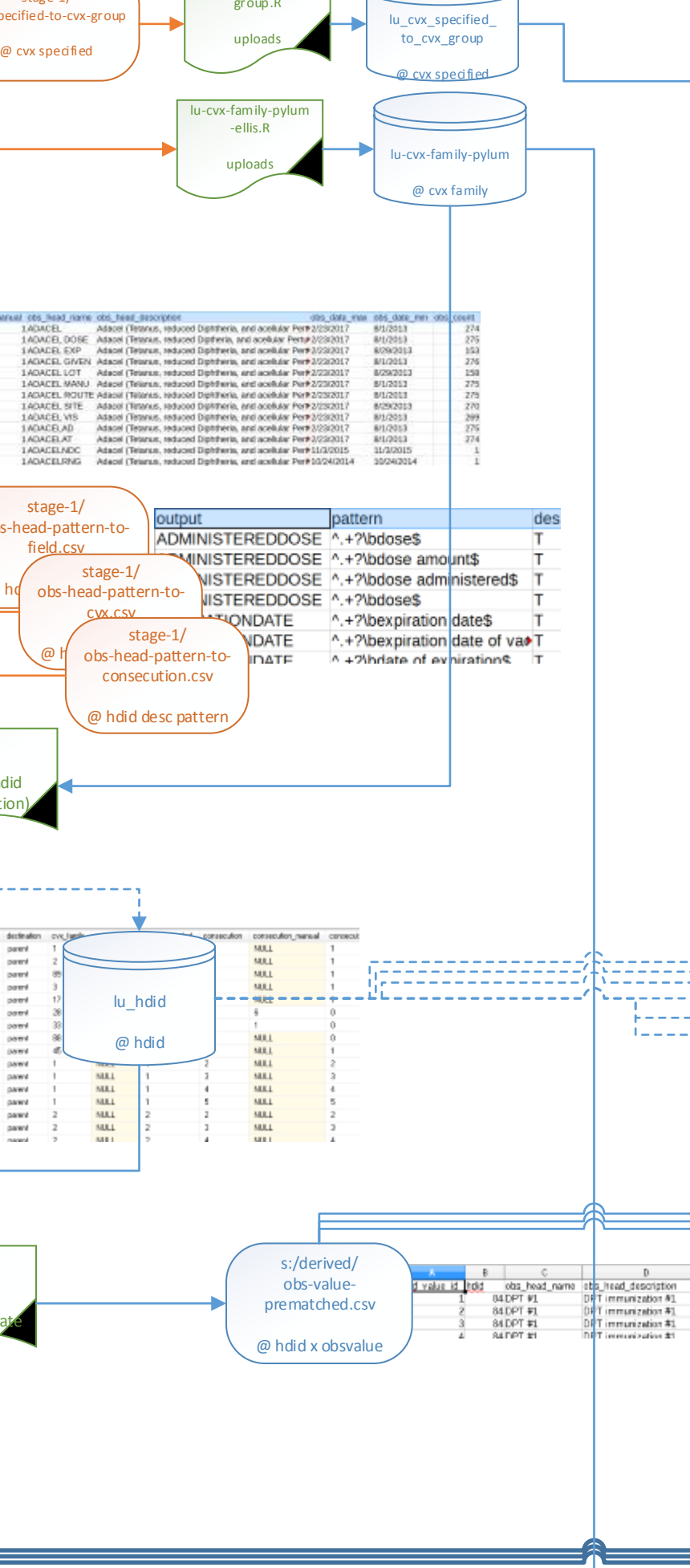

Stage 3: Condense Corroborating Information

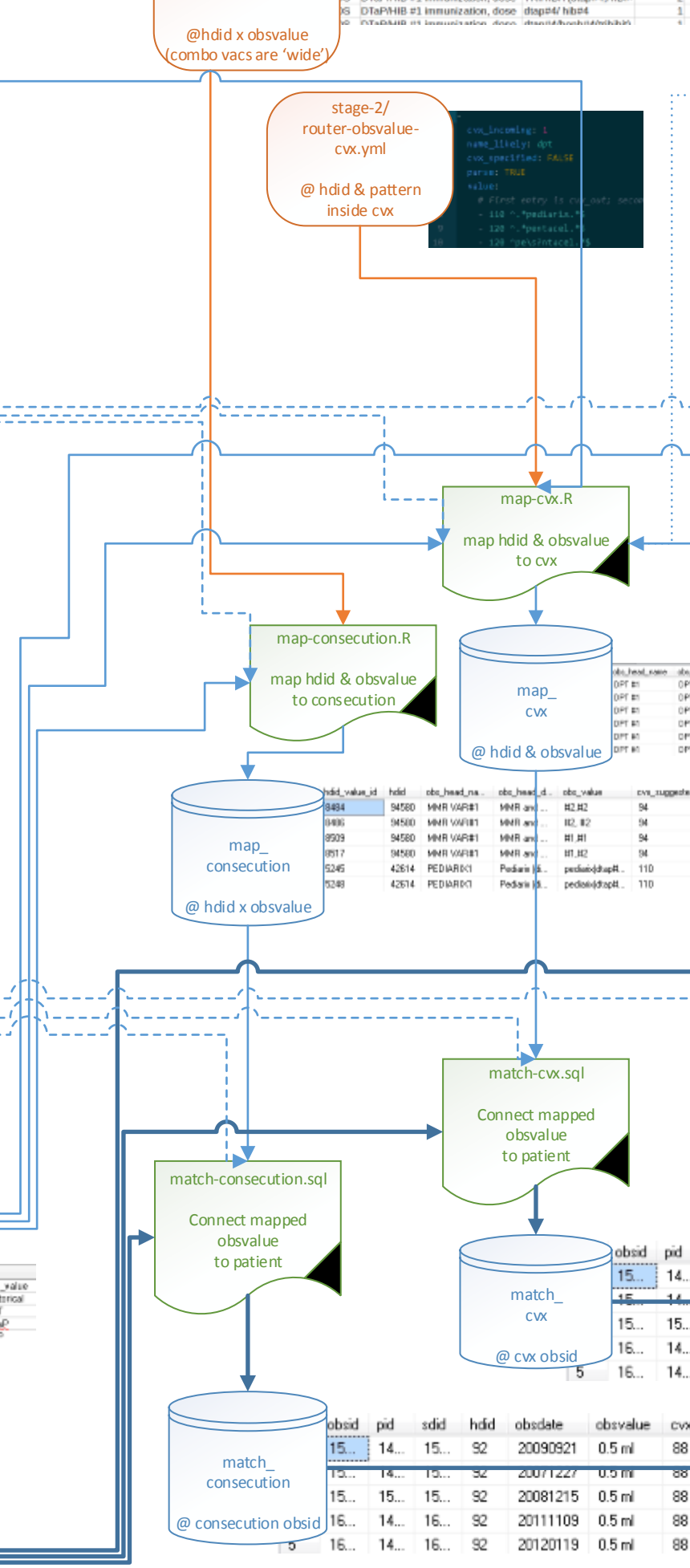

Stage 4: Unify Centricity EMR

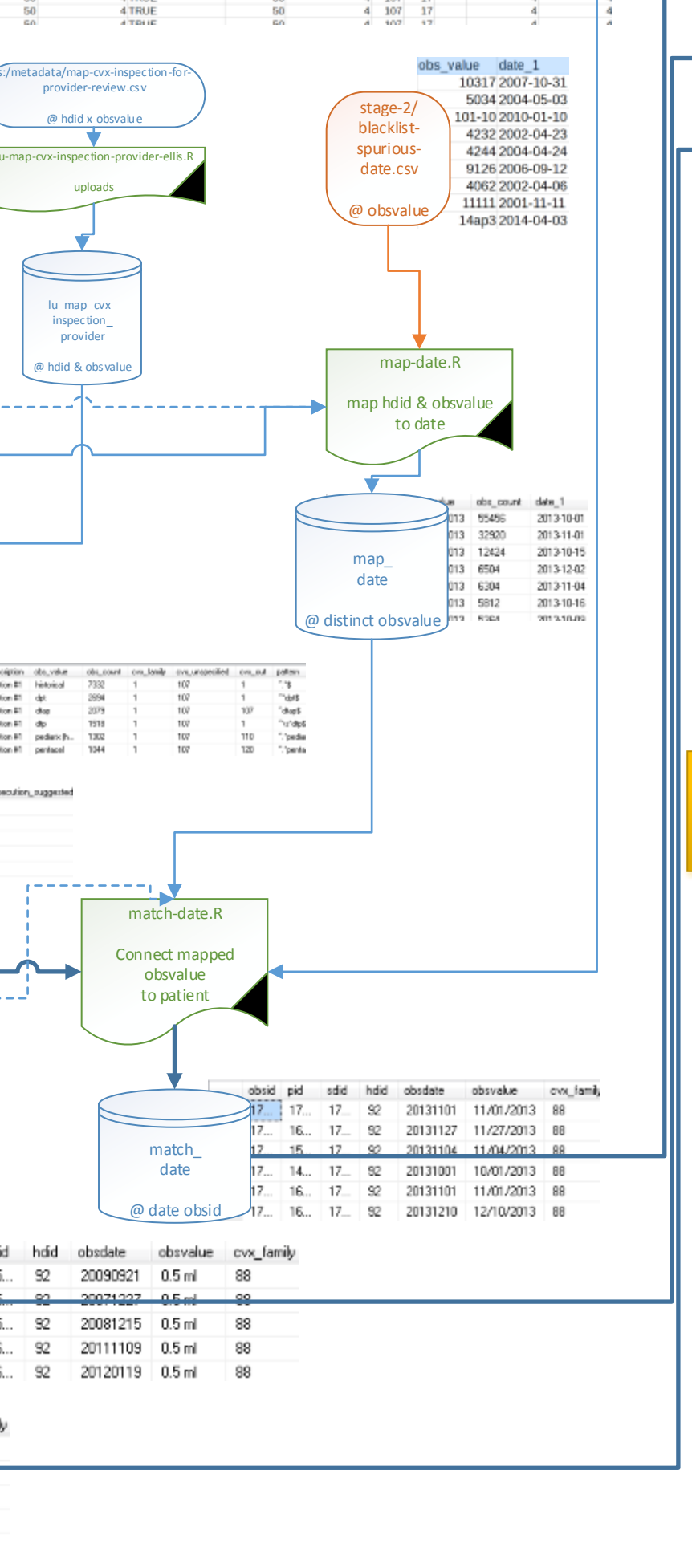

Stage 5: Integrate with IDX/GECEB

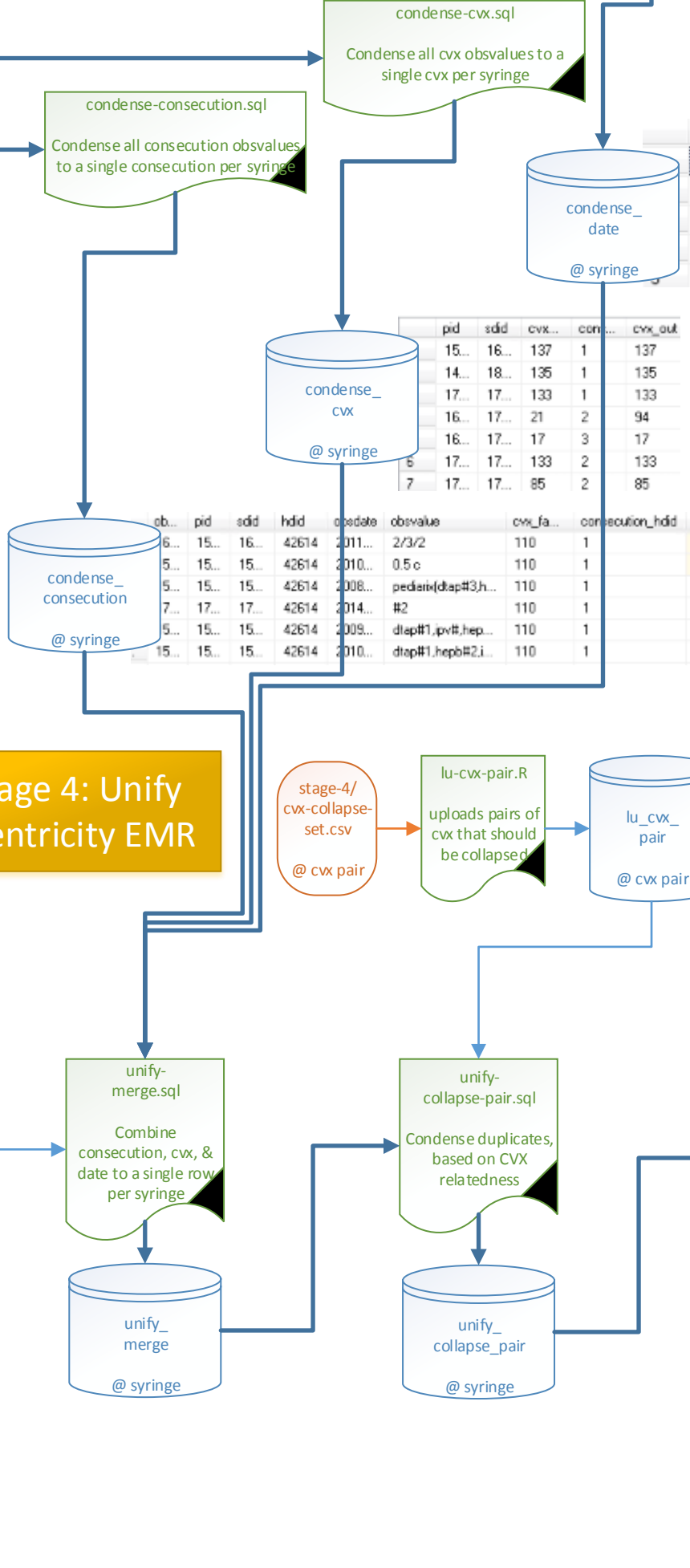

Stage 6: Supplement with OSIS

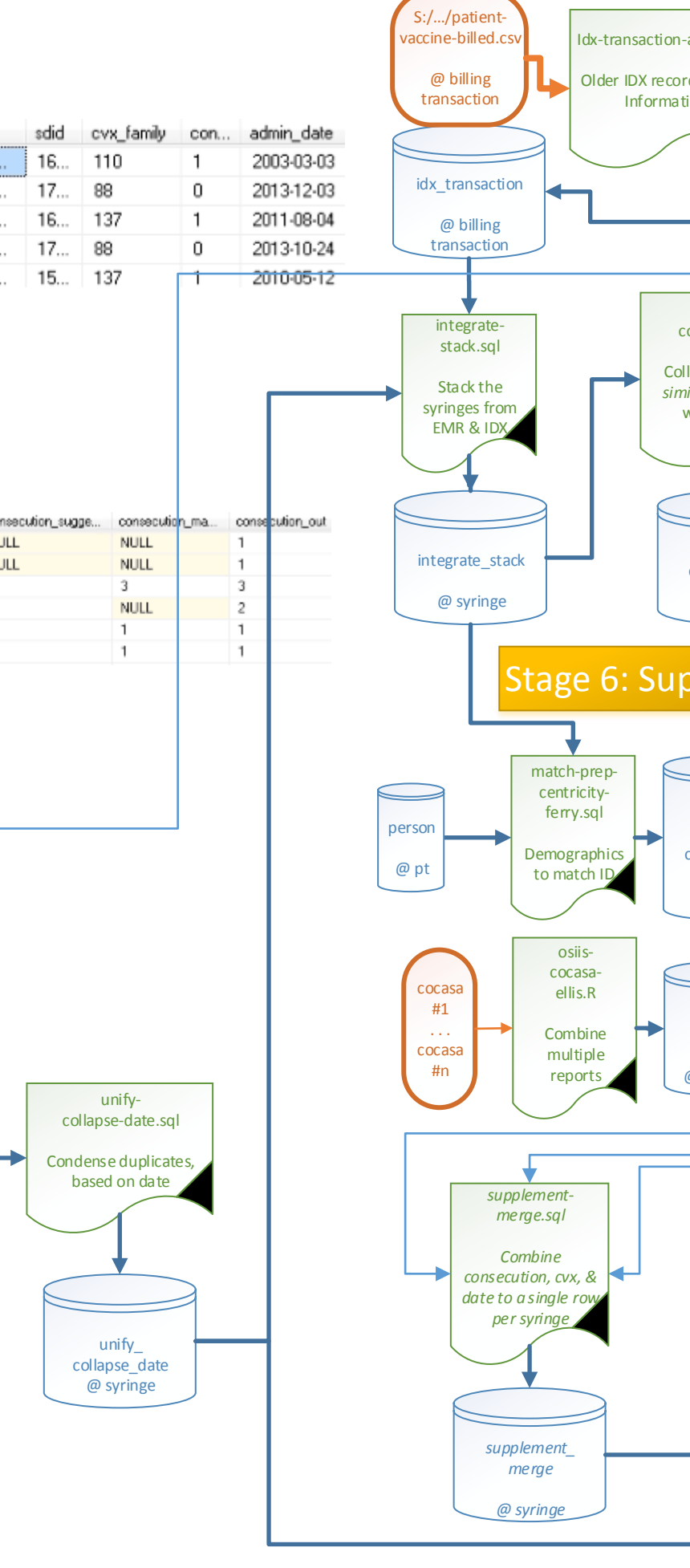

Stage 7: Incorporate Manual Overrides

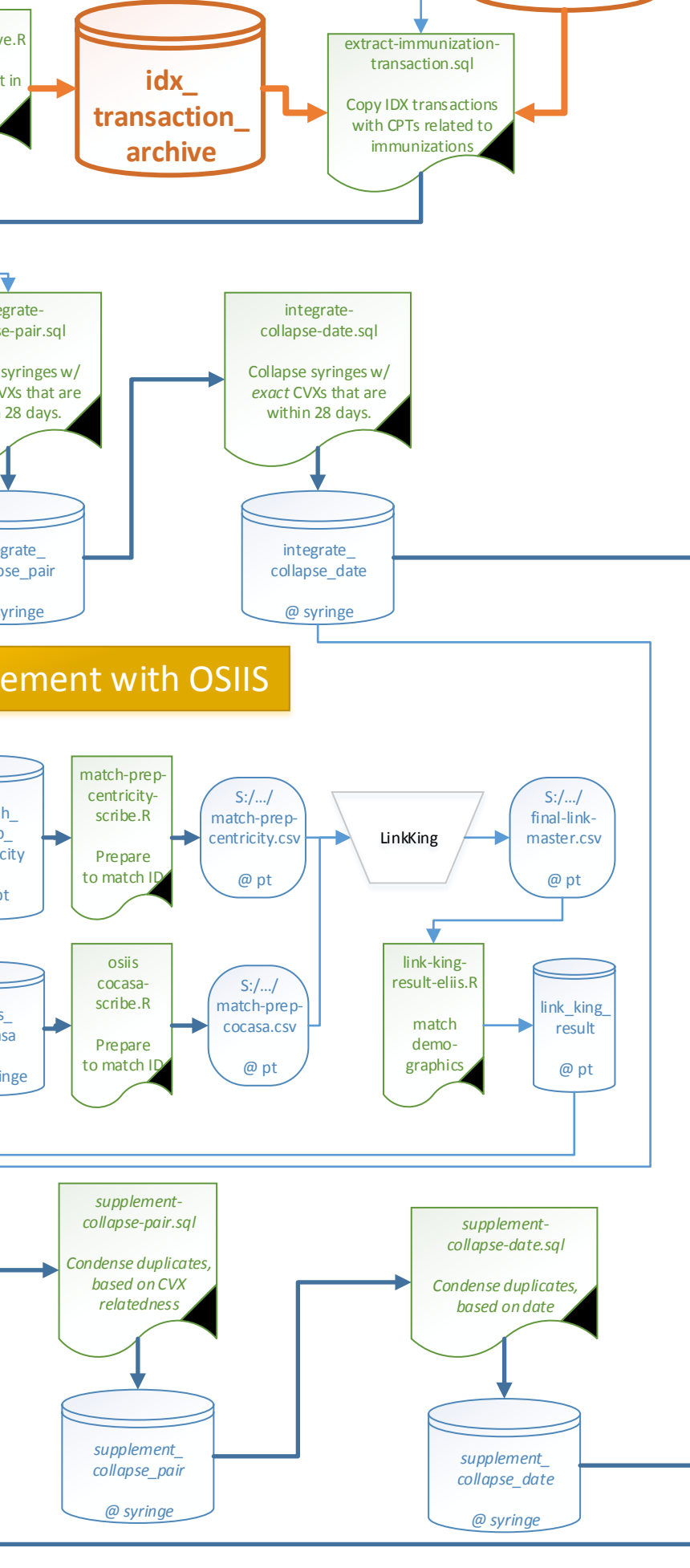

Stage 8: Verify

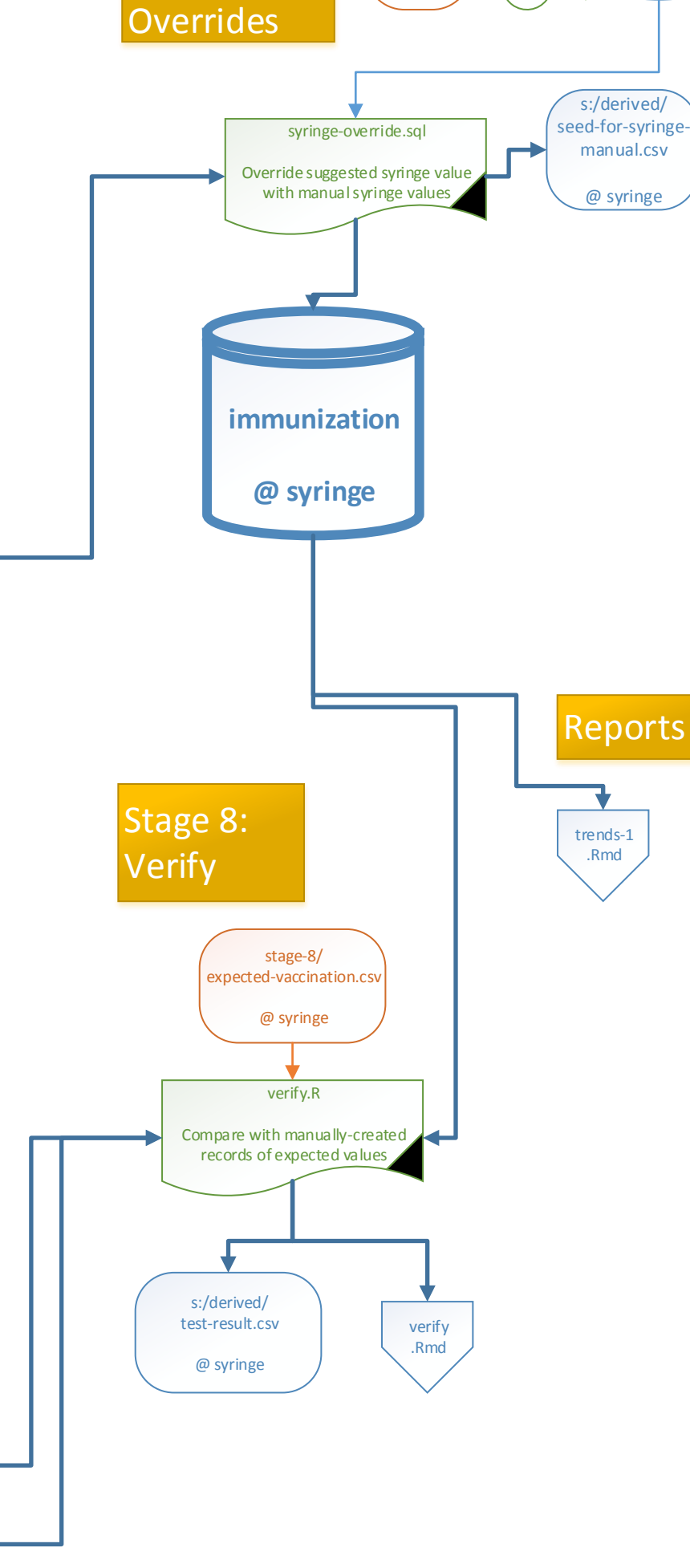

Reports

